

NEXUS P20

Driver for ON/OFF electronic expansion valve



User and maintenance manual

ENGLISH

READ AND KEEP

Rel. 1

CONTENTS

INTRODUCTION

Page 4	1.1	General
Page 4	1.2	Product identification codes
Page 5	1.3	Overall dimensions
Page 5	1.4	Identification data

CHAP. 1

INSTALLATION

Page 6	2.1	General warnings for the installer
Page 6	2.2	Mechanical fixing

CHAP. 2

TECHNICAL FEATURES

Page 7	3.1	Technical features
--------	-----	--------------------

CHAP. 3

WARRANTY TERMS

Page 8	4.1	Warranty terms
--------	-----	----------------

CHAP. 4

DATA PROGRAMMING

Page 9	5.1	Display description
Page 10	5.2	MyPego app interface
Page 13	5.2.1	Connections setup
Page 18	5.2.2	Instrument sharing
Page 19	5.3	Web interface / http access
Page 23	5.4	Remote console interface (optional)
Page 23	5.4.1	Remote console icons (optional)
Page 24	5.4.2	Remote Console Key Combination (Optional)
Page 25	5.5	ESH set point setting and display
Page 26	5.6	First level programming
Page 26	5.7	First level parameter list
Page 28	5.8	Second level programming
Page 28	5.9	Second level parameter list
Page 32	5.9.1	Valve management (EEV parameter)
Page 33	5.10	Quick view menu (read-only)
Page 33	5.11	Quick view menu parameter list (read-only)
Page 33	5.12	Refrigerant temperature table
Page 34	5.13	Password function
Page 34	5.14	Software update
Page 34	5.15	Parameters export/import

CHAP. 5

OPTIONS

Page 35	6.1	TeleNET monitoring/supervision system
Page 35	6.2	Network configuration with Modbus-RTU protocol

CHAP. 6

DIAGNOSTICS

Page 36	7.1	Diagnostics
---------	-----	-------------

CHAP. 7

ANNEXES

Page 37	A.1	EU Declaration of Conformity
Page 38	A.2	Connection diagram
Page 39	A.3	Layout and description of sensors

CHAPTER 1: INTRODUCTION

GENERAL

1.1

DESCRIPTION:

The **NEXUSP20** is an electronic regulator for controlling the ON/OFF electronic expansion valve with 230/110/24 VAC or 24 VDC coil, with integrated connectivity functions through the myPego app.

It manages the most common ON/OFF electronic expansion valves and integrates evaporator superheat management.

APPLICATIONS:

- Refrigerated counters and cold rooms.

MAIN FEATURES:

- Bluetooth, Wi-Fi and ethernet connectivity for installer interaction with the driver and diagnostics.
- Without console on board: the myPego APP is used for programming. An external console with IP65 protection can be connected as a service terminal.
- ON/OFF electronic expansion valve control with 230/110/24 VAC and 24 VDC coil.
- Compatible with 23 gases: R404, R134, R22, R407A, R407F, R407H, R410A, R450A, R507, R513A, R744(CO2), R449A, R290, R32, R448A, R452A, R600, R600A, R1270, R1234ze, R23, R717(NH3), R454C.
- RS485 serial connection with TeleNET or Modbus-RTU protocol, selectable by parameter.
- Three configurable digital inputs.
- Suction temperature and evaporation pressure probe for evaporator superheat management.
- Easy parameter programming with 4 pre-configurations for different applications of the electronic expansion valve.
- Alarm signalling.
- Auxiliary relay configurable as alarm / solenoid valve command.
- Password function.
- LED indications of the system status.
- User-friendly keypad.
- USB input for Parameters export/import and Software update.

PRODUCT IDENTIFICATION CODES

1.2

NEXUSP20

Electronic regulator to control the ON/OFF electronic expansion valve. Manages the most common 230/110/24 VAC and 24VDC ON/OFF electronic expansion valves. Bluetooth, Wi-Fi and ethernet connectivity for installer interaction with the driver and Diagnostics. Evaporator superheat management.

200NANOTTL01

TTL remote console (**optional**).

1.3

OVERALL DIMENSIONS

Dimensions in mm.

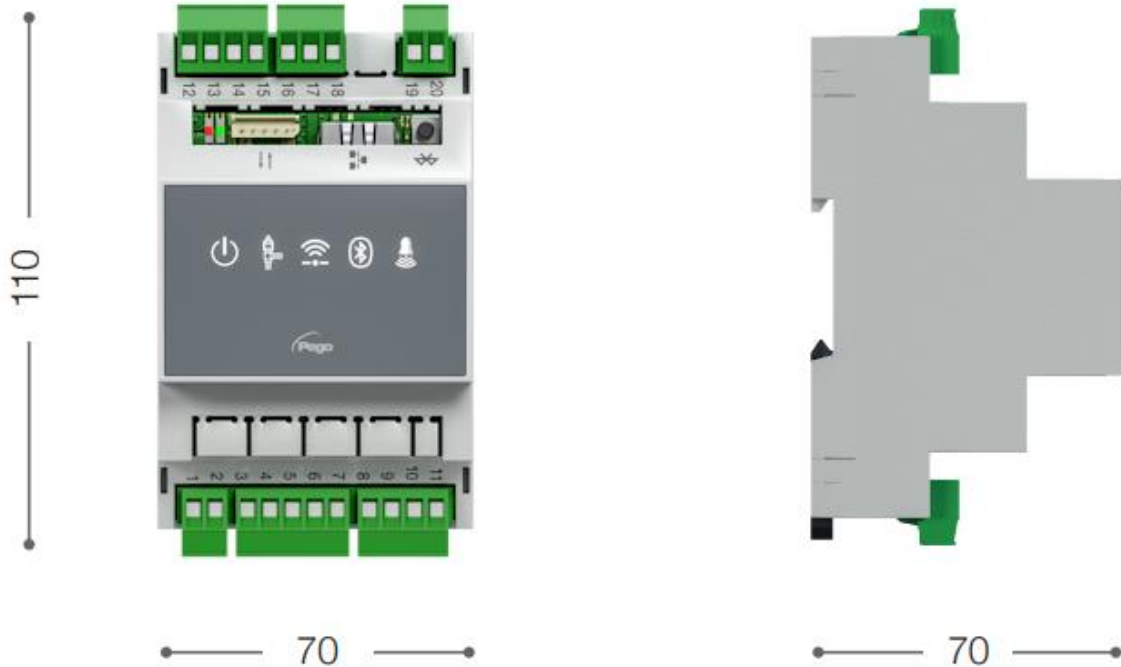



1.4

IDENTIFICATION DATA

The device described in this manual has a plate on one side bearing the identification data:

- Name of Manufacturer
- Code and model of the device
- Serial number
- Date of manufacture
- Power supply

	MADE IN ITALY	
	Description: NEXUSP20 PULSE EEV	
RoHS compliant	Code: NEXUSP20	
	S.N. : 23000000001	
	MFG Date: 12/07/2023	
	P. Supply: 24V~ +/-10% 50-60Hz	

CHAPTER 2: INSTALLATION

GENERAL WARNINGS FOR THE INSTALLER

2.1

1. Install the device in places that respect its degree of protection.
2. Avoid using multi-pole cables with conductors connected to inductive and power conductors and signal conductors like sensors and digital inputs.
3. Avoid putting in the same channels, power cables with signal cables (sensors and digital inputs).
4. Reduce the lengths of the connection cables as much as possible, preventing the wiring from taking the spiral shape harmful for possible inductive effects on electronics.
5. All electric cables used in wiring must be properly proportionate to support the load that must feed.
6. If it's necessary to prolong the probes cable, the use of appropriate section conductors, and in any case not less than 1mm², is necessary. The extension or shortening of the probes could alter the factory calibration. Then proceed with the verification and calibration by means of an external thermometer.

MECHANICAL FIXING

2.2

Place the Module on DIN guide and close the lower hook to block it on it.

Make all electric connections according to the attached patterns for the corresponding model (see the relative tables in attachments). During the wiring it is recommended to keep the power cables away from those of the signal.

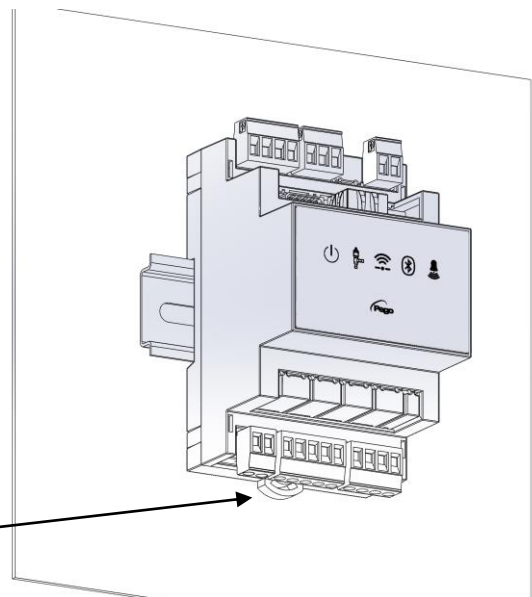

CHAPTER 3: TECHNICAL FEATURES

3.1

TECHNICAL FEATURES

Power supply	
Main Voltage	24 V~ ± 10% 50-60Hz
Max power consumption (electronic control only)	~ 7 VA
Climatic conditions	
Operating temperature	-5T50°C <90% R.H. non-condensing
Storage temperature	-10T70°C <90% R.H. non-condensing
General features	
Compatible types of temperature sensor	Temperature sensors: NTC 10K 1% / PTC / PT1000
Resolution of temperature sensors	0,1 °C
Precision of temperature sensor detection	± 0,5 °C
Range of temperature sensor detection	-45 ÷ +99 °C
Compatible type of pressure sensor	Pressure sensor: 4/20mA
Output features	
Description	Features of output board
Alarm (voltage-free contact)	(8A AC1 Relay) 8(3)A 250V~
Pulse valve	Triac
Dimensional features	
Dimensions	12.15cm x 7.1cm x 10.5cm (HxPxL)
Remote console dimensions (optional)	3.7cm x 2.31cm x 9.3cm (HxPxL)
Insulation and mechanical properties	
Nexus degree of protection	IP20
Degree of protection of the front of the remote console (front mounted)	IP65
Material of boxes	UL94 V-0 self-extinguishing PC+ABS
Type of insulation	II Class

The **NEXUS** electronic controls are covered by a 24-months warranty against all manufacturing defects as from the date indicated on the product ID code.

In case of defect the product must be appropriately packaged and sent to our production plant or to any authorized Service Center with the prior request of the Return Authorization Number.

Customers are entitled to have defective products repaired, spare parts and labour included. The costs and the risks of transport are at the total charge of the Customer. Any warranty action does not extend or renew its expiration.

The Warranty does not cover:

- Damages resulting from tampering, impact or improper installation of the product and its accessories.
- Installation, use or maintenance that does not comply with the instructions provided with the product.
- Repair work carried out by unauthorized personnel.
- Damage due to natural phenomena such as lightning, natural disasters, etc.

In all these cases the costs for repair will be charged to the customer.

The intervention service in warranty can be refused when the equipment is modified or transformed.

Under no circumstances **Pego S.r.l.** will be liable for any loss of data and information, costs of goods or substitute services, damage to property, people or animals, loss of sales or earnings, business interruption, any direct, indirect, incidental, consequential, damaging, punitive, special or consequential damages, in any way whatsoever caused, whether they are contractual, extra contractual or due to negligence or other liability arising from the use of the product or its installation.

Malfunction caused by tampering, bumps, inadequate installation automatically declines the warranty. It is compulsory to observe all the instructions in this manual and the operating conditions of the product.

Pego S.r.l. disclaims any liability for possible inaccuracies contained in this manual if due to errors in printing or transcription.

Pego S.r.l. reserves the right to make changes to its products which it deems necessary or useful without affecting its essential characteristics.

Each new release of the PEGO product user manual replaces all the previous ones.

As far as not expressly indicated, is applicable the Law and in particular the art. 1512 C.C. (Italian Civil Code).

CHAPTER 5: DATA PROGRAMMING

5.1

DISPLAY DESCRIPTION



ENABLING ICON

Led OFF = Enable input OFF (see In1/2/3 configuration)
Led ON = Enable input ON (see In1/2/3 configuration)



EEV OUTPUT STATUS ICON

Led OFF = Valve closed
Led ON = Valve open



WEB CONNECTION ICON

Led OFF = Internet connection not active
Led ON = Internet connection active (Wi-Fi or ethernet)



BLUETOOTH ICON

LED OFF = Bluetooth off
Flashing LED = Bluetooth on, waiting for connection
Led ON = Bluetooth on, smartphone connected



ALARM ICON

Led OFF = No alarm present
Flashing LED = Alarm present

The **myPego** app is the official Pego application for the control and supervision of NEXUS line instruments. It is available for free on the App Store and Google Play Store.



My Pego® App



Direct connection to the device via Bluetooth BLE; monitoring system status; changing parameters and configuring Ethernet Wi-Fi connectivity.



Cloud connection: monitoring of the status of all devices registered in the subscription plan; reading parameters and daily history; receiving real-time alarm notifications from all registered devices.

Note: full control with cCL=2.

Direct connection via Bluetooth

Choosing Bluetooth Connection, accesses the direct connection pages. Enable Bluetooth on the instrument by pressing the appropriate button (see attachment A.2) and confirm the connection in the app to access the instrument status page.

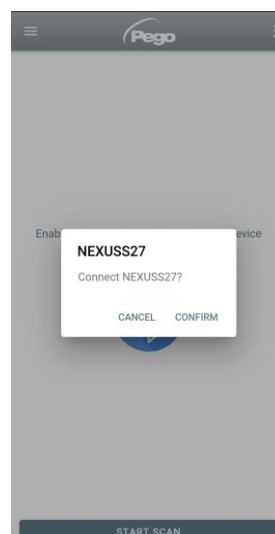
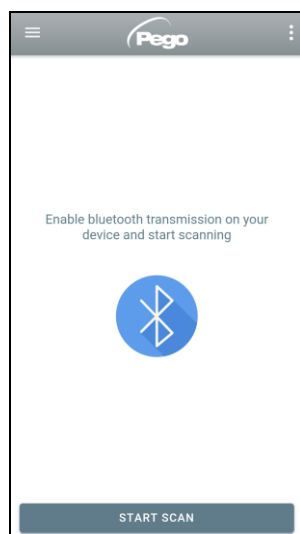

Connecting to Cloud Device

Choosing the Cloud Connection accesses the tool selection page. Here it is possible to select which of the registered instruments (through the procedure indicated in the previous chapter) it is possible to access to monitor the status of the system.

The  icon indicates that the tool is successfully transmitting data to the cloud. Tap the name of a tool to access its status page.

Note: If the icon is grey, it may be necessary to set the date and time correctly on the instrument (parameters Hr, min, Yr, Mo, dy).

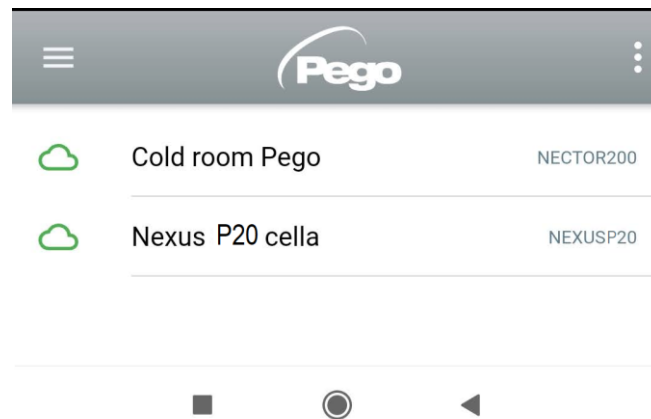

NEXUS P20 instrument status

Once logged in (via Bluetooth if it's a nearby instrument or via Cloud if it's a remote instrument) the NEXUSP20 status page opens.

Here it's possible to:

- Read the current superheat value.
- Read the setpoint and modify it (if connected via Bluetooth or if cCL=2).
- Check the status of inputs/outputs/alarms.
- Verify the main quantities relating to the expansion in the evaporator, in real time:
 - tS4: suction probe temperature
 - tS5: evaporation temperature (converted)
 - PS5: evaporation pressure
 - oEV: electronic valve opening %

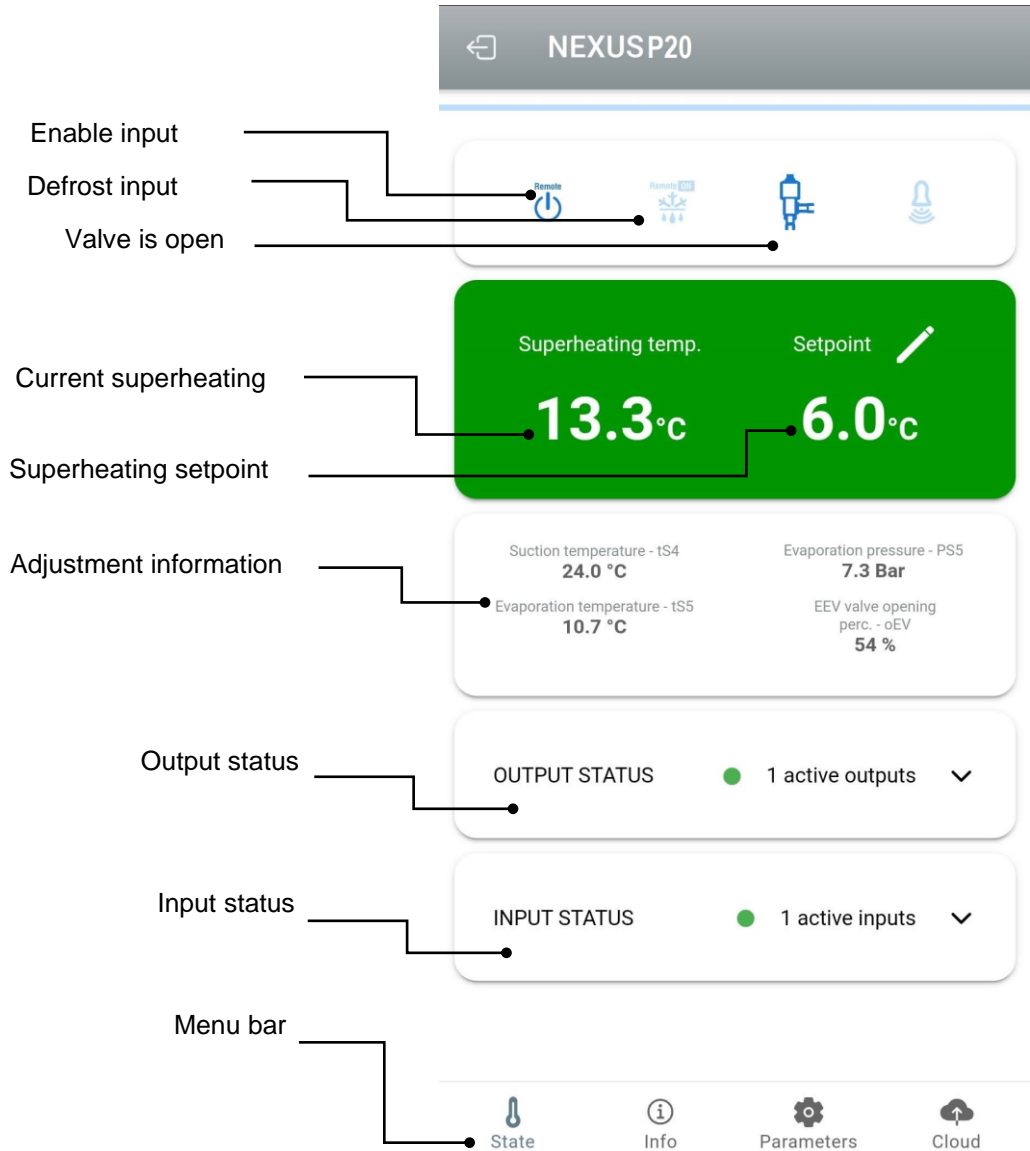

By touching the keys on the bottom bar it's possible to access the other configuration pages:

- Info page

It contains the basic information of the instrument and the name by which the instrument is identified on the Cloud.

Instrument name on cloud, editable if connected via Bluetooth.

Manual: link to download the user manual in pdf.

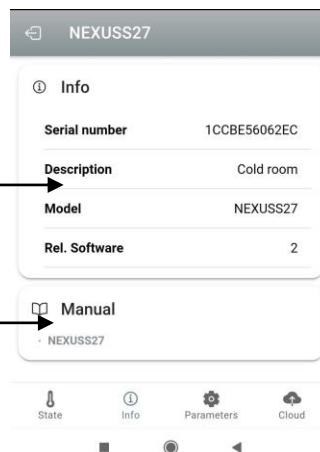

Parameters page

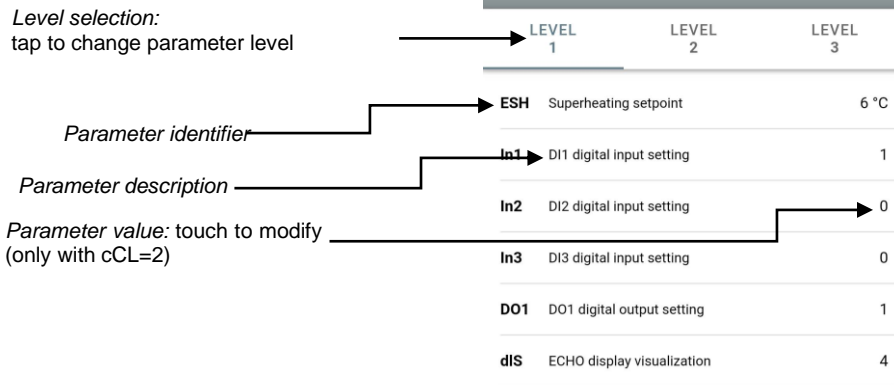

Cloud page

Allows the configuration of the connection to the cloud and the network settings (see the Chapter Connections setup).

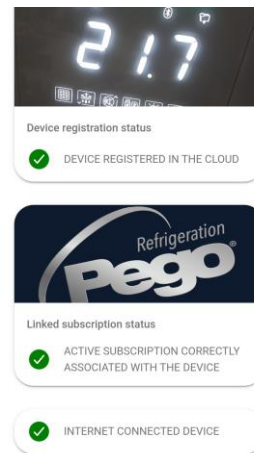

5.2.1

CONNECTIONS SETUP

The NEXUS controller is equipped with Bluetooth BLE, Wi-Fi or ethernet connectivity for management or monitoring via remote devices (tablet, smartphone, PC).

In particular, the remote management of the device takes place in the following ways:

	Distance	Support	Channel	Mode
MyPego app (BLE)	approx. 50m	Smartphone, Tablet	Bluetooth BLE	Control and monitoring
MyPego app (Cloud)	---	Smartphone, Tablet	Wi-Fi, Ethernet	Real-time monitoring and notifications. Control, if cCL=2.
Integrated webserver	---	Smartphone, Tablet, PC	Wi-Fi, Ethernet	Control (with cSL=2) and monitoring. Network configuration required.

The myPego app is available on Google and Apple stores for free.

It allows complete control of the NEXUS instrument and is necessary to carry out the basic operations to connect the device to the Internet (IP address check, Wi-Fi username and password entry, etc.). Through the same application it's possible to receive notifications from NEXUS instruments in the event of an alarm and monitor the status of the registered devices (subscription function, see the dedicated chapter).

To connect the NEXUS instrument to the internet via Wi-Fi or ethernet, do the following:

- 1) Download the **myPego** app from the Google/Apple store and install it on a smartphone/tablet.
- 2) Activate Bluetooth on the NEXUS instrument with the dedicated activation key. The flashing  icon activates.

- 3) Open the **myPego** app and access the Bluetooth section.



- 4) Touch the "Scan" key and the "Confirm" key to make the connection. The Bluetooth icon  on the instrument turns on steady to signal the connection.

- 5) The homepage of the application opens, where it is possible to see the superheat and consult the status of the inputs and outputs.

- 6) In the selection bar below, tap the "Cloud" icon to access the network configuration menu.

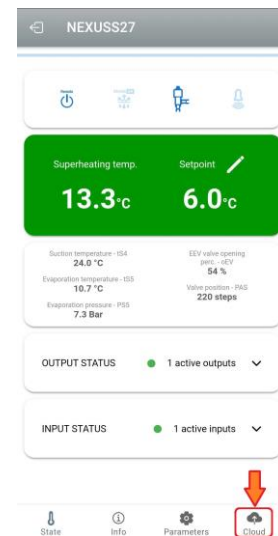

- 7) Upon first sign in, the myPego app prompts setting up of your Cloud connection. If relevant, continue by pressing the "Ok" key otherwise press "Cancel" and skip directly to step 14).

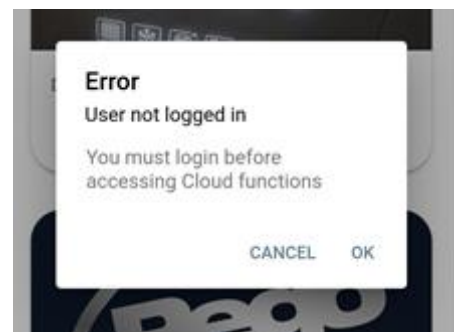

8) By clicking “Ok” in the previous point, the Login page opens. If already registered, enter the registration e-mail and password and click Login. Otherwise click "Sign in" to make the first registration.

E-mail *

Password *

Sign in

Recover password

LOGIN

9) If you are registering for the first time, please enter a valid e-mail address and password.

A verification email will be sent to the address indicated: click on the link in the email to confirm the registration.

Once registration is confirmed, you will be able to log in with the account created (see point 8).

E-mail *

Password *

Password confirm *

CREATE ACCOUNT



10) Once the user has been created (or logged in with an existing user), the device must be associated with an existing Cloud subscription; or create a new subscription. Touch the second link to associate the device with the registered user's cloud subscription.



11) If the user does not have an active cloud subscription, the subscription activation page opens.

Select the type of plan you need based on the number of instruments you want to monitor. Continue with the activation of the plan through the payment page.

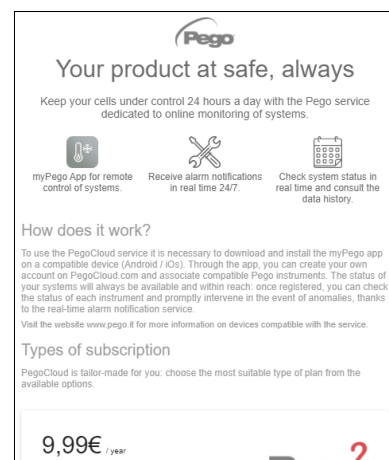

12) Enter your payment details (only the methods provided in the app are available).

The charge will take place only after the trial period and it is possible to interrupt the renewal of the subscription at any time.

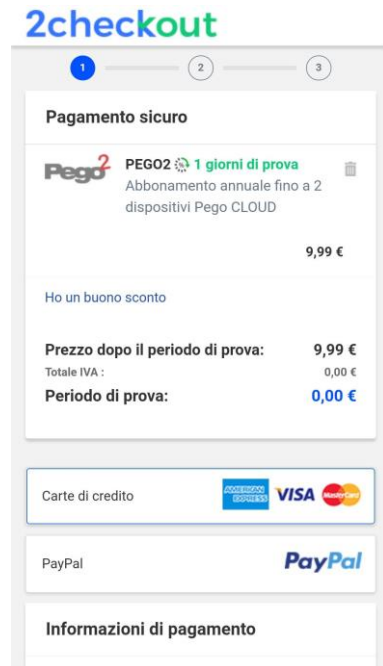

13) Once the subscription plan has been created, it is possible to associate the instrument with the Cloud.

Then return to the "Cloud" page of the app (Bluetooth side) and associate the device by clicking on the second tab. Turn the NEXUS off and on again.

The device is thus associated with the subscription, but to allow data transmission it is necessary to configure the Wi-Fi / Ethernet connection to the internet.

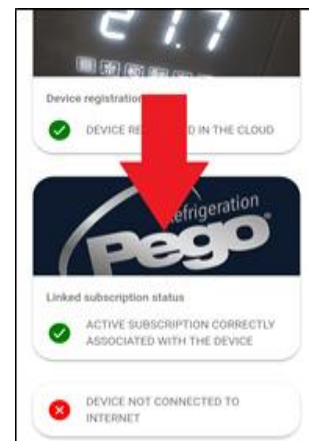

14) Touch the last link at the bottom "DEVICE NOT CONNECTED TO THE INTERNET" to configure the connection.



15) Configure the type of connection:

- **If ethernet connection:**

connect the cable to the NEXUS instrument and set the DHCP or set the desired IP / NETMASK / GATEWAY configuration. At the end, touch the "Send settings" key to configure the instrument. If DHCP is activated, it will be necessary to return to this page after a few moments, to check the IP received from the DHCP server.

- **If Wi-Fi connection:**

touch the WI-FI ON switch and configure the SSID and password of the network to which the NEXUS will connect. Enable DHCP if needed.

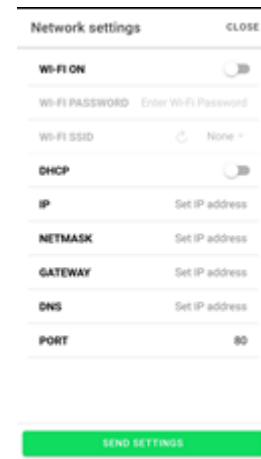

At the end of the setting, touch the "Send settings" key.

16) At the end of the configuration, when the instrument is connected (via Wi-Fi or ethernet) the  icon is activated (after about one minute). You may need to power cycle your NEXUS.

17) If the Cloud connection was configured (see point 13), after a few moments the  icon is activated to signal that the device is correctly sending data to the Pego Cloud.

The "Instrument Sharing" function allows you to share the NEXUS with other users (up to 3) even if they are not subscribers (it's sufficient that each user has their own account).

Sharing users:

- receive alarms and notifications.
- can check the status of the NEXUS device.
- can send commands and modify parameters (if cCL=2).

To share, the instrument must be correctly registered in the Cloud.

Note: It's not possible to log in with the same user from multiple different devices at the same time.

- 1) Open the tool in the Cloud section of the myPego app, go to the Cloud page and select the last link ("Share the device in the Cloud").

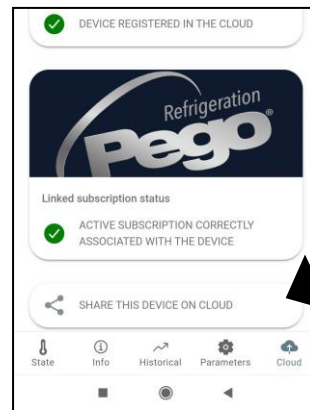

- 2) Touch the (+) symbol to add a shared user; in the window that appears enter the email address of the user with whom you want to share the NEXUS. Touch the "Share" button to share.

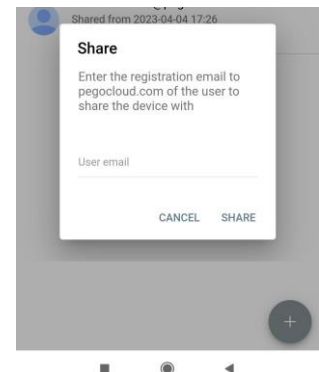
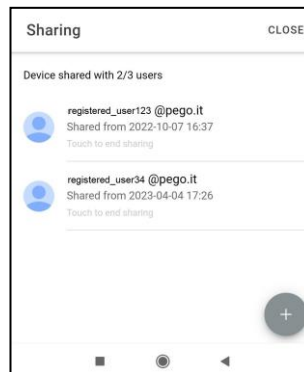

- 3) If sharing is successful, the shared user is added to the list. You can share your NEXUS with up to three users.

Note: the owner can stop sharing at any time by touching the icon next to the shared user.

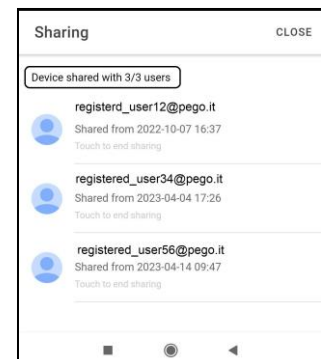
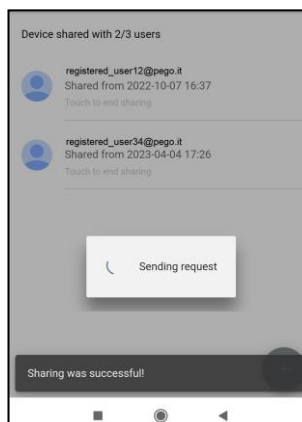

The NEXUS instrument integrates a web server which allows the monitoring and modification of the parameters through a normal web browser or direct http interface. To access the instrument's website, you need to know its IP address using the procedure described in the "Connections setup" chapter (via the myPego app => Bluetooth connection => cloud card).

HTTP ACCESS

By sending properly formatted requests with the http protocol to the IP address of the device, it is possible to access information in real time, change parameters, send commands, etc. Access to this feature is password protected. Below is an example of communication between a third-party system (which sends the request) and the NEXUS (which sends the response).

Request:

```
http://IP1.IP2.IP3.IP4/ajax_data.cgi?pgd='passcode'
```

Answer:

```
{"temp": "23.8", "sttmp": "-0.5", "bg_temp": "1", "stby": "0", "ligh": "0", "def": "0", "almst": "0", "recst": "0"}
```

temp =	current room temperature	sttmp =	temperature setpoint
bg_temp =	reserved	stby =	stand-by status
ligh =	cold room light status	def =	defrost status
almst =	alarm present	recst =	active registrations

For further information, refer to the dedicated manual to be requested from Pego.

WEB SERVER

Type the local IP address of the connected instrument in the address bar of the web browser: the access page appears. Access to the NEXUS homepage is subject to access control using a username and password.

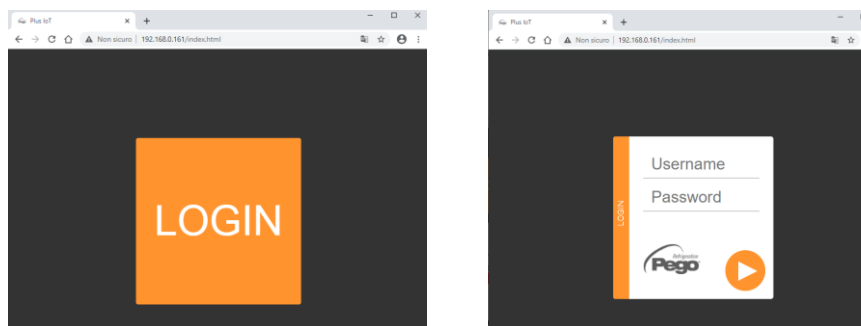

The NEXUS web pages can be accessed in two ways, based on the value of the cSL parameter (1st level parameters):

- If **cSL=1**, normal user: by entering the string "admin" in the "Username" field and the value set in the "PA" parameter in the "Password" field (1st level, e.g. if PA=6 enter the password: "006") is accessed in read-only mode. The modification of the parameters, the setpoint and the manual activation of the outputs (e.g. light, defrost, etc.) are therefore inhibited.
- If **cSL=2**, Administrator user: inserting the string "admin" in the "Username" field and the value set in the "PA" parameter in the "Password" field (3rd level, e.g. if PA=6 insert password: "006") you have full access to the functions. It's therefore possible to modify the parameters and access all the functions.

The web interface consists of a few fixed sections:

- left: page navigation menu.
- above: page name, serial number and type of connected user.
- right: page content.

- Main page

The screenshot shows the main page of the NEXUS P20 web interface. The interface is divided into several sections:

- Page navigation menu:** Located on the left side, it includes links for Live, I/O, Command, Setup, Info, and Logout.
- Current page:** The main content area displays the current page name 'Live' and the serial number 's/n: 1CCBE56062EC- admin'.
- Current superheat (and temperature setpoint):** A large blue box displays the current temperature as 13.3 °C and the setpoint as 6.0 °C.
- Access type (admin or user):** The serial number and user type are displayed in the top right corner.
- Logout:** A button labeled 'Logout' is located in the bottom left corner of the navigation menu.
- Alarm signalling:** A section labeled 'Alarms' is located below the temperature display, showing three icons: a green power button, a green key, and a grey snowflake.

Copyright © Pego S.r.l.

- I/O (Inputs / Outputs)

The screenshot shows the 'I/O' section of the NEXUS interface. It features a sidebar with navigation options: Live, I/O, Command, Setup, Info, and Logout. The main content area is titled 'I/O' and includes the device serial number 's/n: 1CCBE56062EC- admin'. Below the title, there are two sections: 'Analogue inputs' and 'Digital outputs'. The 'Analogue inputs' section contains a table with 9 rows, each representing an input terminal (IN 1 to IN 9), its description, and its current value. The 'Digital outputs' section shows 'OUT 1' with the label 'Alarm'. A copyright notice 'Copyright © Pego S.r.l.' is visible at the bottom of the interface.

Analogue inputs		
IN 1	Suction Temperature Probe (S4)	24.0 °C
IN 2	Evaporation Temperature Probe (S5)	10.8 °C
IN 3	Evaporation Pressure Probe (S5)	7.4 Bar
IN 4	Overheating temperature (tSH)	13.2 °C
IN 5	% EEV valve opening	100
IN 6	Number of steps	410
IN 7	Door switch	●
IN 8	Disabled	●
IN 9	Disabled	●

Digital outputs

OUT 1	Alarm	
-------	-------	--

Input/output terminal PIN

Input / output description (digital or analog)

Input/output status

If digital:

- green: input / output active
- grey: input / output not active

If analog: the analog input or output value is displayed.

- Commands => Parameters

The screenshot shows the 'Parameters' section of the NEXUS interface. It features the same sidebar as the previous screenshot. The main content area is titled 'Parameters' and includes the device serial number 's/n: 1CCBE56062EC- admin'. Below the title, there is a list of parameters, each with a downward-pointing arrow indicating it is a dropdown menu. A callout box points to the arrow next to 'Level 3'.

Parameters menu
Click on the arrow to view the parameter list.

- Setpoint ▼
- Level 1 ▼
- Level 2 ▼
- Level 3 ▼
- Probes Level ▼

NEXUS P20

Parameter code	Parameter description	Current value	Increases value	or decreases value
In1	Digital input 1 configuration	1	+	-
In2	Digital input 2 configuration	0	+	-
In3	Digital input 3 configuration	0	+	-

- Setup

On the "Setup" page it's possible to configure the language of the webserver.





The screenshot shows the "Setup" page of the NEXUS webserver. The page title is "NEXUS" and the user is logged in as "s/n: 1CCBE56062EC- admin". The "Language" section displays four options: ITA (Italy), ENG (England), GER (Germany), and SPA (Spain). Each option is represented by a flag icon and its corresponding language code.

- Info

The screenshot shows the "Info" page of the NEXUS webserver. The page title is "NEXUS" and the user is logged in as "s/n: 1CCBE56062EC- admin". The contact information for Pego S.r.l. is displayed, including the website (www.pego.it), email (info@pego.it), and phone number (+39)0425762906.



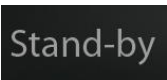

200NANOTTTL01



- 1**  **UP KEY**
 Increase values / Scroll up parameters.
 Silence the audible alarm if present / Acquire an alarm.
- 2**  **DOWN KEY**
 Decrease values / Scroll down parameters
- 3**  **STAND BY KEY**
 The NEXUS P20 instrument **cannot** be paused with this key but only by removing the enabling from the digital input or from LAN.
- 4**  **SET KEY**
 View the set point.
 Allows you to set the SUPERHEATING setpoint if pressed in combination with the Down key or the UP key.
 Resets the audible alarm, if present.

5.4.1

REMOTE CONSOLE ICONS (OPTIONAL)

- 5**  **DISPLAY**
 View the values / parameters
- 6**  **DEFROST CALL ICON**
 Led OFF = Defrost input OFF
 Led ON = Defrost input ON
- 7**  **EEV OUTPUT STATUS ICON** Electronic valve output status
 Led OFF = Motorized valve closed
 Led ON = Motorized valve open
- 8**  **“PRG” ICON**
 Flashing LED = In programming

9

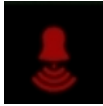

"ALARM PRESENT" ICON

Led OFF = No alarm present.
 Led ON = Alarm triggered and then reset.
 Flashing LED = Alarm present.

REMOTE CONSOLE KEY COMBINATION (OPTIONAL)

5.4.2



EXIT PROGRAMMING

If pressed simultaneously for more than 3 seconds inside any programming menu, they save the settings made by exiting the menu itself.

When the menu is exited, a confirmation BEEP is generated.



1st LEVEL PROGRAMMING

If pressed simultaneously for more than 3 seconds, they allow access to the 1st level programming menu.

When entering the menu, a confirmation BEEP is generated.

This menu is exited automatically after 30 seconds of keyboard inactivity or by pressing the up arrow + down arrow (exit confirmation beep).



2nd LEVEL PROGRAMMING (EEV parameters)

If pressed simultaneously for more than 3 seconds, they allow access to the 2nd level programming menu.

When entering the menu, a confirmation BEEP is generated.

This menu is exited automatically after 30 seconds of keyboard inactivity or by pressing the up arrow + down arrow (exit confirmation beep).



USB MANAGEMENT LEVEL (Parameter export / import)

If pressed simultaneously for more than 3 seconds, they allow access to the USB management menu for parameters export/import and software update.

When entering the menu, a confirmation BEEP is generated.

This menu can be exited by selecting the "nO" item (exit confirmation beep).

QUICK VIEW MENU (READ ONLY)

If pressed simultaneously for more than 3 seconds, they allow access to the quick display menu.

When entering the menu, a confirmation BEEP is generated.

Within this menu, the up and down arrows allow you to scroll through the various parameters.

Pressing the Set key alternates the display of the parameter with its value.

With the parameter value displayed, pressing the up or down arrows still leads to the display of the next or previous parameter to the current one.

This menu is exited automatically after 2 minutes of keyboard inactivity or by pressing the up arrow + down arrow (exit confirmation beep).

**5.5****ESH SET POINT SETTING AND DISPLAY****Via the myPego app:**

1. Open the myPego app and connect to the instrument called "NEXUSS27" via Bluetooth or via cloud.
2. The superheat setpoint is immediately visible on the homepage, on the right. To change the value, touch the pencil next to the value. ESH SETPOINT range: 0.1 – 25°C.

With remote console:

1. Press the SET key to display the current SETPOINT value (ESH).
2. By keeping the SET key pressed and pressing one of the keys (▲) or (▼) the value of SETPOINT ESH is changed.

Release the SET key to return to displaying the ESH temperature, the modifications made will be stored automatically. ESH SETPOINT range: 0.1 – 25°C.

Via the myPego app:

1. Open the myPego app and connect to the instrument called "NEXUSP20" via Bluetooth or via cloud.
2. Touch the "Parameters" button in the bottom toolbar.
3. Consult / modify the parameters of the desired level.

With remote console:

To access the first programming level, press and hold down the UP (▲), DOWN (▼) and STAND-BY keys for more than 3 seconds. When the first programming parameter appears:

1. Select with the (▲) key or the (▼) key the parameter to be modified. After selecting the desired parameter, you will be able to:
 - Display the setting by pressing the **SET** key.
 - Change the setting by holding down the **SET** key and pressing one of the (▲) or (▼) keys.
2. Once the configuration values have been set, to leave the menu, press and hold the (▲) and (▼) keys for a few seconds until the cold room temperature value reappears. The menu can also be exited after 30 seconds of inactivity on the keyboard.
3. Changes made to the parameters will be automatically saved when leaving the configuration menu.

The regulation of the valve continues even when you are inside the menu.

LIST OF FIRST LEVEL PARAMETERS (Installer level)

PAR.	MEANING	VALUES	DEFAULT
In1	Digital input DI1 setting and activation status.	4 = emergency closing (N.O.) 3 = tPF % fixed opening (N.O.) 2 = Defrost (N.O.) 1 = ON Driver EEV (N.O.) 0 = Disabled -1 = ON Driver EEV (N.C.) -2 = Defrost (N.C.) -3 = tPF % fixed opening (N.C.) -4 = emergency closing (N.C.)	1
In2	Digital input DI2 setting and activation status.	- Same legend as In1 values -	0
In3	Digital input DI3 setting and activation status.	- Same legend as In1 values -	0
DO1	DO1 digital output function setting. Note: By solenoid valve command we mean the normal solenoid valve command, therefore this output becomes the repetition of the ON input of the Driver.	2 = DO1 relay active for solenoid valve command. 1 = DO1 relay active in the presence of an alarm. 0 = DO1 relay disabled. -1 = DO1 relay deactivated in the presence of an alarm. -2 = DO1 relay deactivated for solenoid valve command.	1

PAR.	MEANING	VALUES	DEFAULT
diS	Visualization on the main display	1 = (tS4) Probe visualization (S4) Suction temperature. 2 = (tS5) Probe display (S5) Evaporation temperature. 3 = (PS5) Probe display (S5) Evaporation pressure. 4 = (tSH) Superheating temperature display. 5 = (oEV) valve opening percentage.	4
SEr	Communication protocol on RS-485	0 = TeleNET Protocol 1 = Modbus-RTU Protocol	0
Ad	Network address for connection to the TeleNET / Modbus-RTU supervision system.	0 ÷ 31 if SEr=0 1 ÷ 247 if SEr=1	1
Bdr	Modbus baudrate	0 = 300 baud 3 = 2400 baud 6 = 14400 baud 1 = 600 baud 4 = 4800 baud 7 = 19200 baud 2 = 1200 baud 5 = 9600 baud 8 = 38400 baud	5
Prt	Modbus parity check	0 = none 1 = even 2 = odd	0
bEE	Buzzer enabling	0 = disabled 1 = enabled	1
P1	Password: protection type. Active when PA is other than 0	0 = displays only the set point and allows alarm silencing. Blocks all other functions. 1 = displays the set point, allows the alarms to be silenced, + accesses the quick view menu. 2 = blocks 1st, 2nd and 3rd level programming access (all other functions are allowed). 3 = block access to 2nd and 3rd level programming (all other functions are allowed). 4 = blocks access to 3rd level programming (all other functions are allowed).	4
PA	Password. (see P1 for type of protection).	0...999 0 = Function disabled	0
dy	Day setting	1 ÷ 31	1
Mo	Month setting	1 ÷ 12	1
Yr	Year setting	0 ÷ 99	20
Hr	Time setting	Hour	12
Min	Minute setting	Minutes	0
cE	Network connection type	0 = Ethernet 1 = Wi-Fi	0
cB	Bluetooth Management	0 = Bluetooth disabled 1 = Bluetooth activatable	1
cCL	Cloud management	0 = disabled 1 = active, read only 2 = active, read/write parameters and commands	1
cSL	Local web server management	0 = disabled 1 = active (data display only) 2 = active (data display and command reception)	2

PAR.	MEANING	VALUES	DEFAULT
dEF	Setting the default parameters	<p>Via the myPego app: Send the value "291" to restore the default parameters.</p> <p>With remote console: Position on the dEF parameter and press all the keys for 10 seconds to restore the default parameters.</p>	---
reL	Release software	read only	read only

2nd LEVEL PROGRAMMING (EEV Parameters)

5.8

Via the myPego app:

1. Open the myPego app and connect to the instrument called "NEXUSP20" via Bluetooth or via cloud.
2. Touch the "Parameters" button in the bottom toolbar.
3. Consult / modify the parameters of the desired level.

With remote console:

To access the second programming level, press and hold down the UP (▲) and STAND-BY keys for more than 3 seconds.

When the first programming parameter appears:

1. Select with the (▲) key or the (▼) key the parameter to be modified. After selecting it you will be able to:
 - Display the setting by pressing the **SET** key.
 - Change the setting by holding down the **SET** key and pressing one of the (▲) or (▼) keys.
2. Once the configuration values have been set, to leave the menu, press and hold the (▲) and (▼) keys for a few seconds until the cold room temperature value reappears. The menu can also be exited after 30 seconds of inactivity on the keyboard.
3. Changes made to the parameters will be automatically saved when leaving the configuration menu.

The regulation of the valve continues even when you are inside the menu.

2nd LEVEL PARAMETERS LIST (EEV Parameters)

5.9

PAR.	MEANING	VALUES	DEFAULT
EEV	<p>EEV electronic valve management Settings 1 to 5 load default values in parameters ECt, EPb, Etl, Etd, ELS.</p> <p>For more details, see the table "Loading default settings based on the EEV parameter" at the end of chapter 5.9.</p>	<p>1 = EEV control (default 1) 2 = EEV control (default 2) 3 = EEV control (default 3) 4 = EEV control (default 4) 5 = EEV control (default 5) 6 = EEV control via Modbus (register 1536) 7 = EEV control via 0-10V input</p> <p>(see table on Page 31)</p>	1

PAR.	MEANING	VALUES	DEFAULT
ErE	Type of refrigerant GAS used. Setting this parameter is of fundamental importance for correct operation.	0 = R404 1 = R134 2 = R22 3 = R407A 4 = R407F 5 = R407H 6 = R410A 7 = R450A 8 = R507 9 = R513A 10=R744(CO2) 11 = R449A 12 = R290 13 = R32 14 = R448A 15 = R452A 16 = R600 17 = R600A 18 = R1270 19 = R1234ze 20 = R23 21 = R717(NH3) 22 = R454C	0
ECt	Cycle time It represents the sum of the times of an EEV valve opening / closing cycle. With it, the opening and closing times EEV are calculated. Example: if the EEV valve must be open at 30% we will have that: EEV valve opening time = ECt* 30/100 EEV valve closing time = ECt * (100-30)/100	1 ÷ 20 seconds	6 sec
EPb	Proportional band (gain) PID superheat regulation.	1 ÷ 100%	15%
Etl	Integral time of PID algorithm for superheat regulation.	0 ÷ 500 sec steps of 2 seconds	100 sec
Etd	Derivative time PID algorithm superheat control.	0 ÷ 10,0 sec steps of 0.1 seconds	2,0 sec
EOE	EEV valve opening percentage in event of error with S4 or S5 sensors. This function permits (diminished) control in the event of a fault with one of the control sensors.	0 ÷ 100%	50%
ESO	During the Start-up phase, the EEV valve opens by the ESO percentage for the ESt time.	0 ÷ 100%	85%
ESt	Duration of the Start-up phase. The superheat alarms MOP, LOP and LSH alarms are disabled during this phase.	0 ÷ Edt tenths of seconds	6 tenths of seconds
EdO	After defrosting, the EEV valve opens by the EdO percentage for the Edt time.	0 ÷ 100%	100%
Edt	Duration of EdO valve opening phase after defrosting. The superheat alarms MOP, LOP and LSH alarms are disabled during this phase.	ESt ÷ 250 tenths of seconds	24 tenths of seconds
EHO	Maximum opening percentage of EEV valve. In the case of an oversize valve, this variable permit limitation of maximum opening of the valve at a set percentage.	0 ÷ 100%	100%
EPt	Type of temperature transducer (S4): sets the type of transducer used to detect the temperature (S4)	0 = NTC 1 = PT1000 2 = PTC (-45/80 °C)	0
EP4	Pressure (bar) corresponding to 4mA or 0V. In relation to the Evaporation pressure sensor (S5)	-1.0 ÷ EP2 bar	0.0 bar
EP2	Pressure (bar) corresponding to 20mA or 5V. In relation to the Evaporation pressure sensor (S5)	EP4 ÷ 90.0 bar	12.0 bar
CA4	Calibration of the inlet temperature transducer (S4)	-10,0 ÷ +10,0 °C	0,0 °C
CA5	Calibration of the Evaporation pressure transducer (S5)	-10,0 ÷ +10,0 bar	0,0 bar

PAR.	MEANING	VALUES	DEFAULT
LSH	<p>LSH threshold (low superheat temperature). Superheat values that are too low can cause return of the liquid to the compressor, or extreme oscillations. Below the LSH threshold, the ELS protection forces the PID control to close the valve more quickly and bring the value back up to the superheat setpoint.</p>	0,0 ÷ Set SH °C	2,0 °C
ELS	<p>Low superheat protection. When this is enabled and SH < LSH, the PID integration timer is set based on the selection of 1 to 7 of the ELS. Value 1 is for the quickest closing time. Enabling of this protection starts the SHd counter for activating the LSH alarm. THE LSH PROTECTION TAKES PRIORITY OVER THE LOP PROTECTION. THE LSH PROTECTION IS NOT ACTIVATED DURING THE START-UP PHASE (ES_t TIMER) OR DURING THE DEFROSTING OR POST-DEFROSTING PHASE (Ed_t TIMER)</p>	<p>0 = disables the LSH protection and signalling of the relative LSH alarm. 1 = 5% Etl 2 = 10% Etl 3 = 15% Etl 4 = 20% Etl 5 = 25% Etl 6 = 30% Etl 7 = 35% Etl 8 = 50% Etl 9 = 100% Etl (no correction, and activation only of the LSH alarm).</p>	2
SHd	<p>Activation delay of the superheat alarm: the LSH superheat alarm is triggered only after it has remained active for the SHd time. In the event of an LSH alarm, the valve closes instantly. The alarm is automatically reset and recalled when SH ≥ LSH. When the alarm is active:</p> <ul style="list-style-type: none"> - The LSH message blinks on the display - The buzzer is activated 	0 ÷ 240 tenths of seconds	30
MOP	<p>MOP threshold (Maximum Saturated Evaporation Temperature in relation to the S5 sensor). This represents the maximum saturated evaporation pressure above which the MOP protection is activated (EMO parameter). When MOP protection is enabled, the control closes the valve to limit evaporation temperature and to prevent the thermal protection from stopping the compressor.</p>	(LOP+1) ÷ +45°C	+45°C
EMO	<p>MOP protection (enabled when tS5>MOP). When MOP protection is enabled, the valve abandons its control PID and, for each stage of the cycle, closes by the EMO percentage starting from the opening percentage of the abandoned PID. Enabling of this protection starts the MOd counter for activating the MOP alarm. THE MOP PROTECTION IS NOT ENABLED DURING THE START-UP PHASE (ES_t TIMER) OR DURING THE DEFROSTING OR POST-DEFROSTING PHASE (Ed_t TIMER).</p>	<p>0= disables the MOP protection and relative MOP alarm signal 0 ÷ 100%</p>	0
Mod	<p>MOP alarm activation delay: the MOP alarm is triggered only after the MOP protection has remained active for the MOd time. The alarm is automatically reset when "Temp.S5" ≤ MOP.</p>	0 ÷ 240 tenths of seconds	60

PAR.	MEANING	VALUES	DEFAULT
LOP	LOP threshold (minimum saturated evaporation temperature in relation to the S5 sensor) This represents the minimum saturated evaporation pressure below which the LOP protection is activated. When LOP protection is enabled, the control opens to prevent the compressor from stopping due to low pressure (mechanical pressure switch).	-45°C ÷ (MOP-1)	-45°C
ELO	LOP protection (activated when tS5<LOP) When LOP protection is enabled, the valve abandons its control PID and, for each stage of the cycle, opens by the ELO percentage starting from the opening percentage of the abandoned PID. Enabling of this protection starts the LOd counter for activating the LOP alarm. THE LSH PROTECTION TAKES PRIORITY OVER THE LOP PROTECTION. THE LOP PROTECTION IS NOT ENABLED DURING THE START-UP PHASE (ESt TIMER) OR DURING THE DEFROSTING OR POST-DEFROSTING PHASE (Edt TIMER).	0 = disables the LOP protection and relative LOP alarm signal 0 ÷ 100%	0
Lod	LOP alarm activation delay: the LOP alarm is signaled only after it has remained active for the LOd time. The alarm is self-resetting when " Temp.S5 " ≥ LOP With the alarm active, LOP is flashing on the display.	0 ÷ 240 tenths of seconds	30
tPF	Valve forced positioning. At any time via digital input (if the controller is not in standby) it is possible to force the opening of the valve to a pre-set value.	0 ÷ 100 %	50%

NOTE: all the calculation times of the LSH, MOP, LOP alarms are reset when control is stopped OR DURING THE START PHASE (ESt TIME), DURING THE DEFROST OR POST-DEFROST PHASE (Edt TIME).

Loading default settings based on EEV parameter:

	EEV = 1 DEFAULT PEGO	EEV = 2 (ROOM or TN REFRIGERATED COUNTER control with on-board compressor)	EEV = 3 (ROOM or BT REFRIGERATED COUNTER control with on-board compressor)	EEV = 4 (ROOM or DUCTED TN REFRIGERATED COUNTER control)	EEV = 5 (ROOM or DUCTED BT REFRIGERATED COUNTER control)
ESH	6 °C	6 °C	6 °C	11 °C	11 °C
EPb	15 %	15 %	15 %	15 %	15 %
Etl	100 sec	100 sec	100 sec	150 sec	150 sec
Etd	2,0 sec	2,0 sec	2,0 sec	5,0 sec	5,0 sec
LSH	2 °C	2 °C	2 °C	5 °C	5 °C
ELS	2	2	2	2	2
MOP	+45 °C	5 °C	-15 °C	+5 °C	-15 °C
EMO	0	5	5	5	5
LOP	-45 °C	-25 °C	-45 °C	0	0
ELO	0	15	15	0	0

Setting the EEV parameter from 1 to 5 loads the default values in the **ESH, EPb, Etl, Etd, LSH, ELS, MOP, EMO, LOP, ELO** parameters. In this case the controller acts as a **superheat regulator**, based on the value read by the connected pressure/temperature probes.

Setting value **6** enables the valve position command via Modbus (register 1536): the control imposes the valve opening value received via Modbus and **no superheat control is performed**. In this case it is not necessary to connect the probes and the alarms E4, E5 LSH, MOP, LOP are disabled. The position must be communicated within 60 seconds to avoid closing the valve.

Setting value **7** enables the valve position command via 0-10V input: the control imposes the valve opening value calculated based on the input and **no superheat control is performed**. In this case it is not necessary to connect the probes and the alarms E4, E5 LSH, MOP, LOP are disabled. Connect the 0-10V input to terminals 11 (GND) -12 (+V) of the PEV P20, as indicated in chapter A.2.

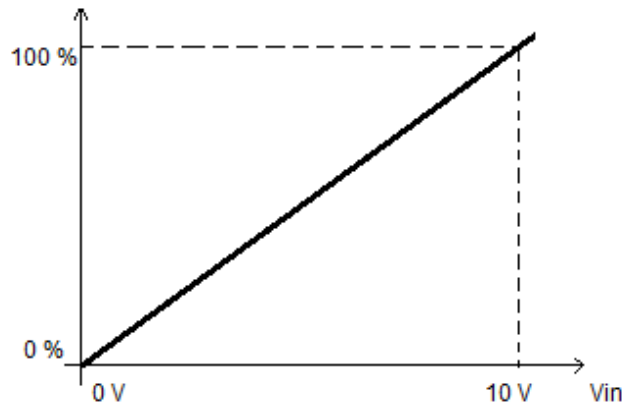

5.10

QUICK VIEW MENU (READ-ONLY)

During the start-up of the system it may be useful to simply check the reading of the various probes or of some values to verify or optimize the process. To access these values:

Via the myPego app:

1. Open the myPego app and connect to the instrument called "NEXUSP20" via Bluetooth or via cloud.
2. The process regulation probes are immediately visible below the superheat value.

With remote console:

To access the quick view menu, press and hold down the DOWN (▼) and STAND-BY keys for more than 3 seconds. Within this menu, the up or down arrows allow you to scroll through the different parameters.

Pressing the Set key alternates the display of the parameter with its value (to facilitate reading, pressing the SET key switches between parameter and value: it is not necessary to keep it pressed). With the value of the parameter displayed, pressing the up or down arrow keys in any case displays the parameter following or preceding the current one (therefore it automatically exits from displaying the value). This menu is exited automatically after 2 minutes of console inactivity or by pressing the up arrow (▲) + down arrow (▼) keys simultaneously for a few seconds.

QUICK VIEW MENU PARAMETER LIST (READ-ONLY)

5.11

PARAMETERS	MEANING	VALUES
tS4	View Inlet Temperature sensor (S4)	(read-only) °C
tS5	View Evaporation Temperature sensor (S5)	(read-only) °C
PS5	View Evaporation Pressure sensor (S5)	(read-only) Bar
tSH	View superheat temperature	(read-only) °C
oEV	EEV valve opening percentage	(read-only) %

5.12

REFRIGERANT TEMPERATURE TABLE

The following table shows the evaporation temperature limits (tS5, see CHAP: 5.11) based on the type of refrigerant fluid set (parameter ErE).

Parameter ErE	Code	Temperature range	Parameter ErE	Code	Temperature range
0	R404	-50 ÷ 70 °C	11	R449A	-50 ÷ 70 °C
1	R134A	-50 ÷ 70 °C	12	R290	-50 ÷ 70 °C
2	R22	-50 ÷ 70 °C	13	R32	-50 ÷ 70 °C
3	R407A	-50 ÷ 70 °C	14	R448A	-50 ÷ 70 °C
4	R407F	-50 ÷ 70 °C	15	R452A	-50 ÷ 70 °C
5	R407H	-50 ÷ 70 °C	16	R600	-20 ÷ 70 °C
6	R410A	-50 ÷ 70 °C	17	R600A	-30 ÷ 70 °C
7	R450A	-40 ÷ 70 °C	18	R1270	-50 ÷ 70 °C
8	R507	-50 ÷ 70 °C	19	R1234ZE	-30 ÷ 70 °C
9	R513A	-45 ÷ 70 °C	20	R23	-50 ÷ 25 °C
10	R744 (CO2)	-50 ÷ 40 °C	21	R717 (NH3)	-50 ÷ 70 °C
			22	R454C	-50 ÷ 70 °C

PASSWORD FUNCTION (only on remote console)**5.13**

The password function is enabled by setting a value other than 0 in the PA parameter. See parameter P1 for the various levels of protection. Protection is enabled automatically when the keypad is not used for 30 seconds. The digits 000 appear on the display. Use the up/down arrow keys to edit the number and press the SET key to confirm. The 000 password window disappears if the keypad is not used for 30 seconds.

Note: If you forget the password, use the universal number **100**.

SOFTWARE UPDATE**5.14**

Contact Pego at: tecnico@pego.it .

EXPORT / IMPORT PARAMETERS**5.15**

It's possible to export / import the parameters set in the NEXUS P20 via the USB port on the board. To do this you need the optional remote display.

- 1) Insert the USB memory into the slot on the board.
- 2) Press the SET + STANDBY keys for 5 seconds and select the item "PrE" to export the parameters, "Pri" to import the parameters from the USB (in this case there must be a previously exported file on the USB memory).
- 3) Press the SET key to confirm. The NEXUS controller automatically exports / imports the set parameters and the device status.

Note: the generated files (name: NEXP20_1.PAR and NE20_ESP.bkp) can be imported to other NEXUS P20 controllers to obtain identically configured instruments.

CHAPTER 6: OPTIONS

TELENET MONITORING/SUPERVISION SYSTEM

6.1

To connect the electrical panel to a **TeleNET** network, follow the diagram below. Refer to the **TeleNET** user manual for instrument configuration.

IMPORTANT: During the configuration, under "Module" select "PEV-PULSE Instrument".

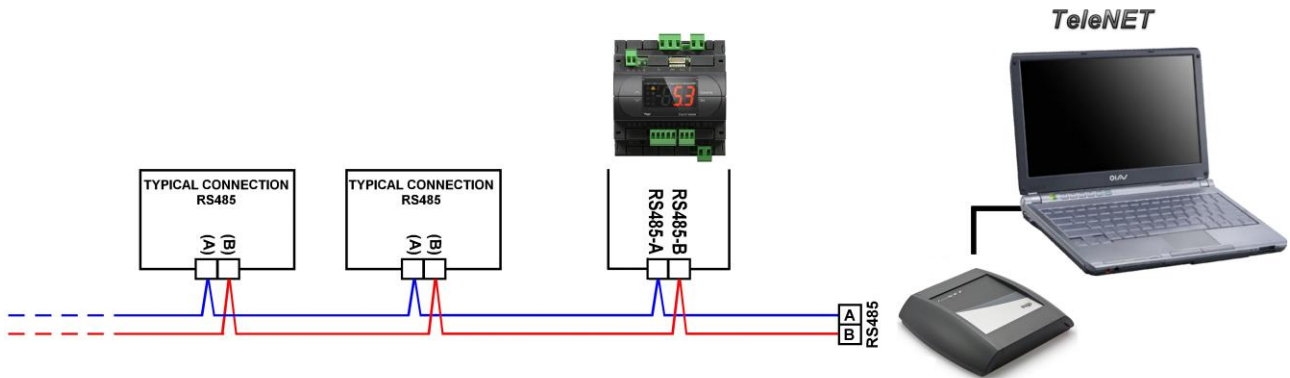

NETWORK CONFIGURATION WITH MODBUS-RTU PROTOCOL

6.2

Connect the board to a RS485 network with **Modbus-RTU** protocol with reference to the diagram below.

Refer to the **MODBUS-RTU_NEXUSP20** manual (available on our website) for the specifications of the MODBUS-RTU communication protocol.

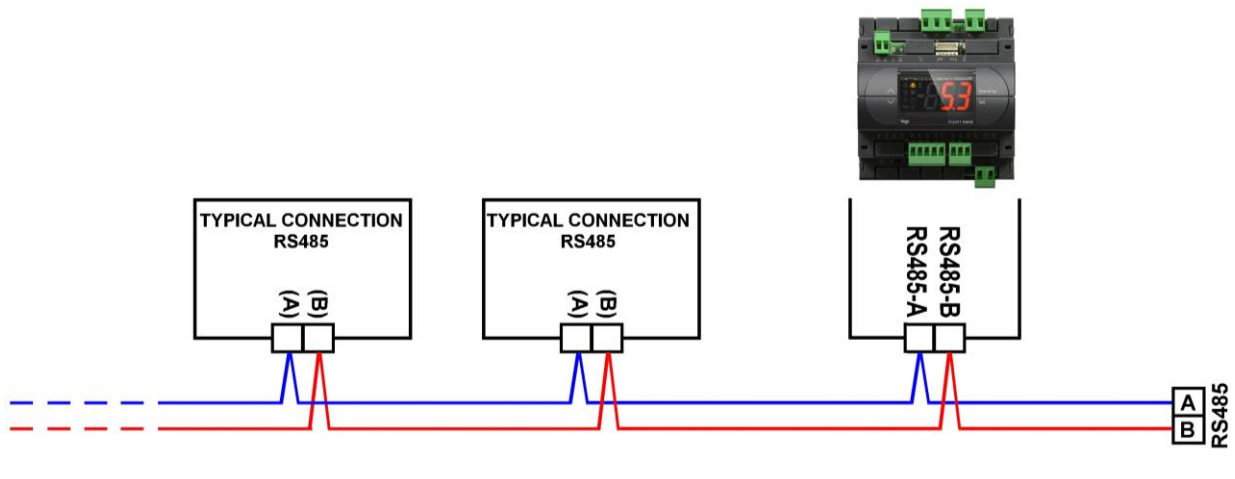

CHAPTER 7: DIAGNOSTICS

7.1

DIAGNOSTICS

In the event of any anomalies, the **NEXUS P20** controller warns the operator through alarm codes displayed on the remote display or with notification via the myPego app.

CODE	POSSIBLE CAUSE	OPERATION TO BE PERFORMED
E4	Functional anomaly of the suction temperature probe (S4).	<ul style="list-style-type: none"> • Check the status of the probe and its connections. • If the problem persists, replace the probe.
E5	Functional anomaly of the Evaporation pressure probe (S5).	<ul style="list-style-type: none"> • Check the status of the probe and its connections. • If the problem persists, replace the probe.
LSH	Low superheat alarm.	<ul style="list-style-type: none"> • Check the status of the refrigeration system. • Modify the PID parameters. • If the problem persists, contact the technical assistance service.
MOP	Alarm for maximum saturated evaporation temperature exceeded, in relation to sensor S5.	<ul style="list-style-type: none"> • Check the status of the refrigerating system. • Edit the PID parameters. • If the problem persists, contact the technical assistance service.
LOP	Alarm for minimum saturated evaporation temperature exceeded, in relation to sensor S5.	<ul style="list-style-type: none"> • Check the status of the refrigerating system. • Edit the PID parameters. • If the problem persists, contact the technical assistance service.
En	No connection between remote display and unit.	<ul style="list-style-type: none"> • Check the connection between the remote display and the unit. • If the problem persists, contact the technical assistance service.
E0 E0i E0E	Eeprom alarm. An EEPROM memory fault has been detected.	<ul style="list-style-type: none"> • Switch unit off and then back on. • Restore the default values (see dEF parameter).
EP1	Lack of power supply Alarm. The emergency close digital input has been activated by the backup module.	<ul style="list-style-type: none"> • Check for the presence of mains power to the backup module. • Check the status of the digital input configured as "Emergency closure".
ES1 C1	Connectivity module alarm.	<ul style="list-style-type: none"> • Turn the equipment off and on again. • If the problem persists, contact the technical support service.
EU1..EU9	USB communication error. An error occurred while exporting/importing data to USB.	<ul style="list-style-type: none"> • Turn the equipment off and on again.

ALLEGATI**DICHIARAZIONE DI CONFORMITA' UE / EU CONFORMITY****A.1**

LA PRESENTE DICHIARAZIONE DI CONFORMITA' È RILASCIATA SOTTO LA RESPONSABILITA' ESCLUSIVA DEL FABBRICANTE:
THIS DECLARATION OF CONFORMITY IS ISSUED UNDER THE EXCLUSIVE RESPONSIBILITY OF THE MANUFACTURER:



PEGO S.r.l. a socio unico - Via Piacentina 6/b, 45030 Occhiobello (RO) – Italy –
 Società soggetta all'attività di direzione e coordinamento di Castel S.r.l.

DENOMINAZIONE DEL PRODOTTO IN OGGETTO / DENOMINATION OF THE PRODUCT IN OBJECT

MOD.: NEXUS P20

IL PRODOTTO DI CUI SOPRA È CONFORME ALLA PERTINENTE NORMATIVA DI ARMONIZZAZIONE DELL'UNIONE EUROPEA:
THE PRODUCT IS IN CONFORMITY WITH THE RELEVANT EUROPEAN HARMONIZATION LEGISLATION:

Direttiva Bassa Tensione (LVD): **2014/35/UE**
Low voltage directive (LVD): 2014/35/EU

Direttiva EMC: **2014/30/UE**
Electromagnetic compatibility (EMC): 2014/30/EU

LA CONFORMITA' PRESCRITTA DALLA DIRETTIVA È GARANTITA DALL'ADEMPIMENTO A TUTTI GLI EFFETTI DELLE SEGUENTI NORME:
THE CONFORMITY REQUIRED BY THE DIRECTIVE IS GUARANTEED BY THE FULFILLMENT TO THE FOLLOWING STANDARDS:

Norme armonizzate: **EN 60335-1:2012, EN 61000-6-1:2007, EN 61000-6-3:2007**
European standards: EN 60335-1:2012, EN 61000-6-1:2007, EN 61000-6-3:2007

IL PRODOTTO È COSTITUITO PER ESSERE INCORPORATO IN UNA MACCHINA O PER ESSERE ASSEMBLATO CON ALTRI MACCHINARI PER COSTITUIRE UNA MACCHINA CONSIDERATE DALLA DIRETTIVA: 2006/42/CE "Direttiva Macchine".
THE PRODUCT HAS BEEN MANUFACTURED TO BE INCLUDED IN A MACHINE OR TO BE ASSEMBLED TOGETHER WITH OTHER MACHINERY TO COMPLETE A MACHINE ACCORDING TO DIRECTIVE: EC/2006/42 "Machinery Directive".

Firmato per nome e per conto di:
Signed for and on behalf of:

Pego S.r.l.
Martino Villa
Presidente

Luogo e Data del rilascio:
Place and Date of Release:

Occhiobello (RO), 01/07/2023

CONNECTION DIAGRAM

A.2

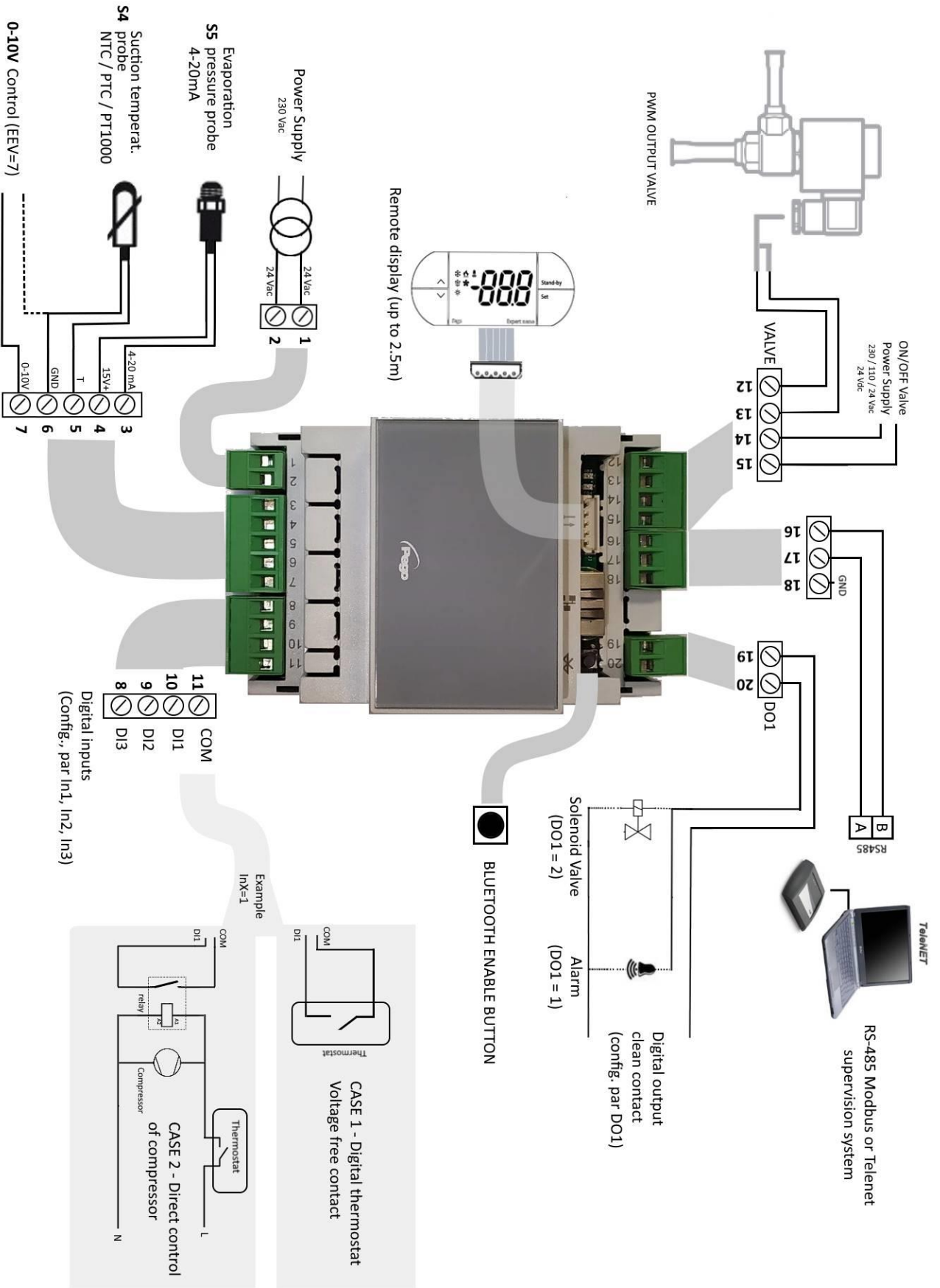

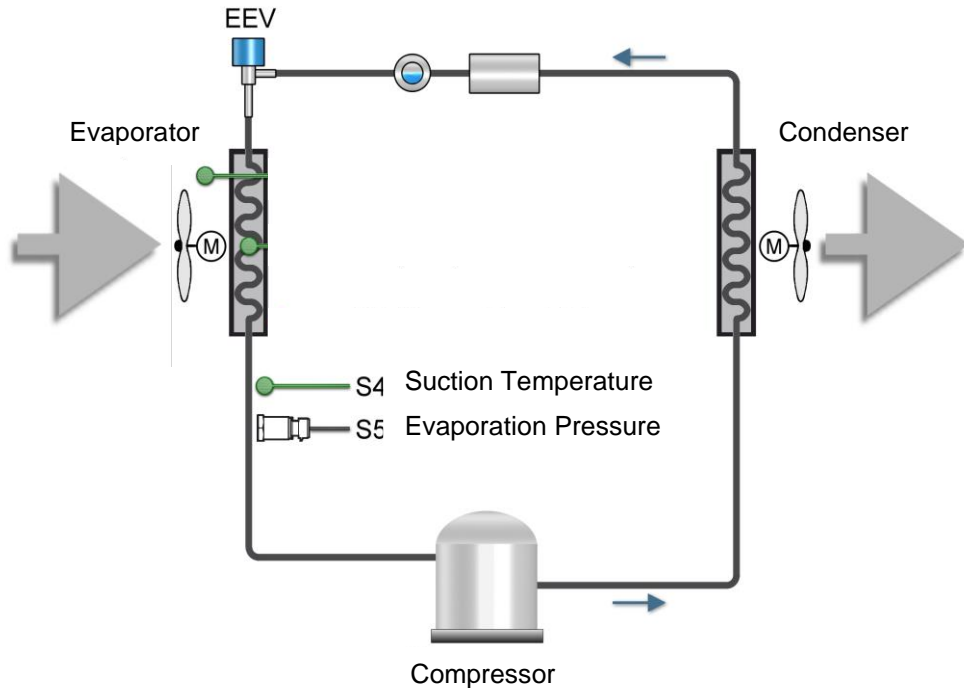



PEGO s.r.l.
Via Piacentina, 6/b 45030 Occhiobello (RO) - ITALY
Phone +39 0425 762906
e-mail: info@pego.it – www.pego.it

TECHNICAL ASSISTANCE
Phone +39 0425 762906 e-mail: tecnico@pego.it

Distributor: